



SHIFTING PATTERN

Resilienz & Continuity Management in der Multi-Cloud

Steven Henzen (T-Systems CH)

Mai 2021



LIFE IS FOR SHARING.

PATTERN SHIFT VOM HAUSTIER ZUM NUTZTIER

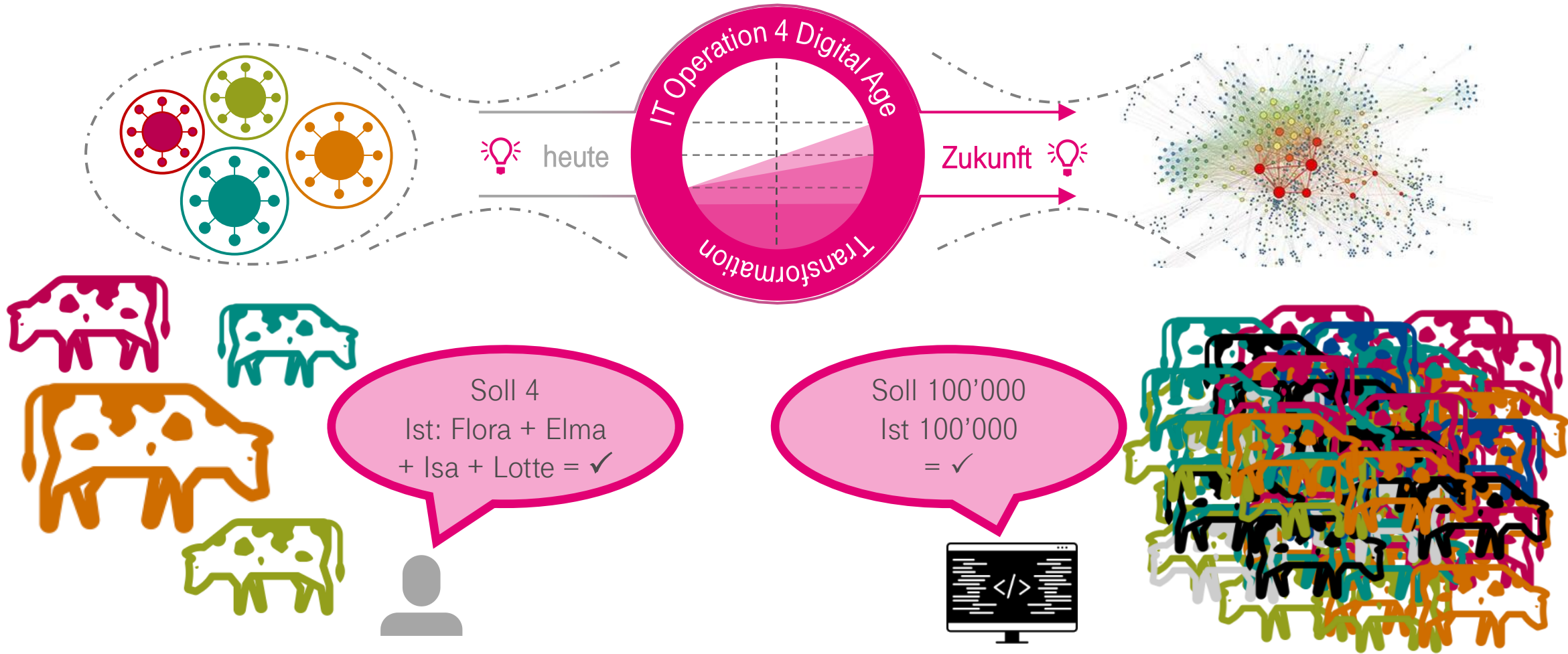

IT OPERATION 4 DIGITAL AGE

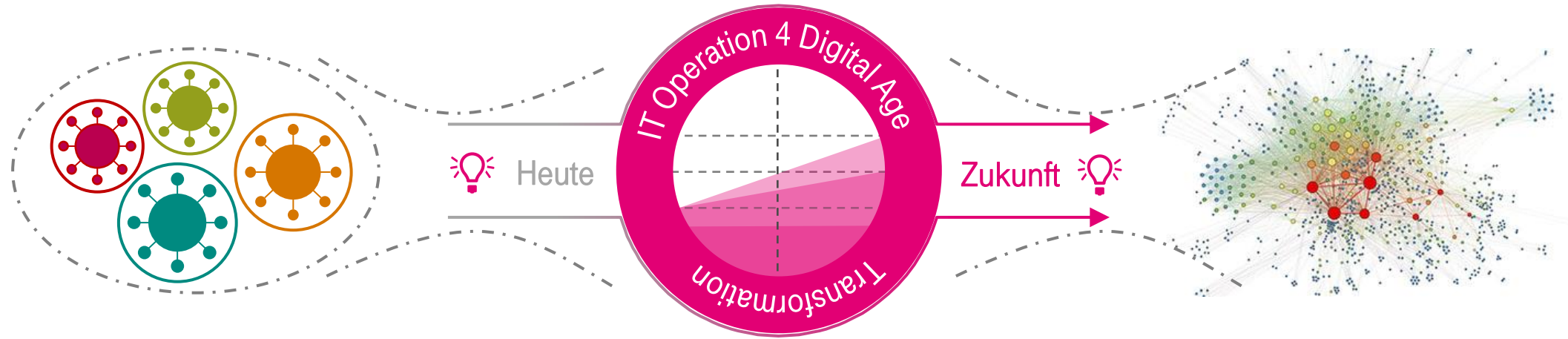

Cloud Native Trail



SMART TECHNOLOGY BACKBONE

Fokus auf Resilienz & Service Continuity

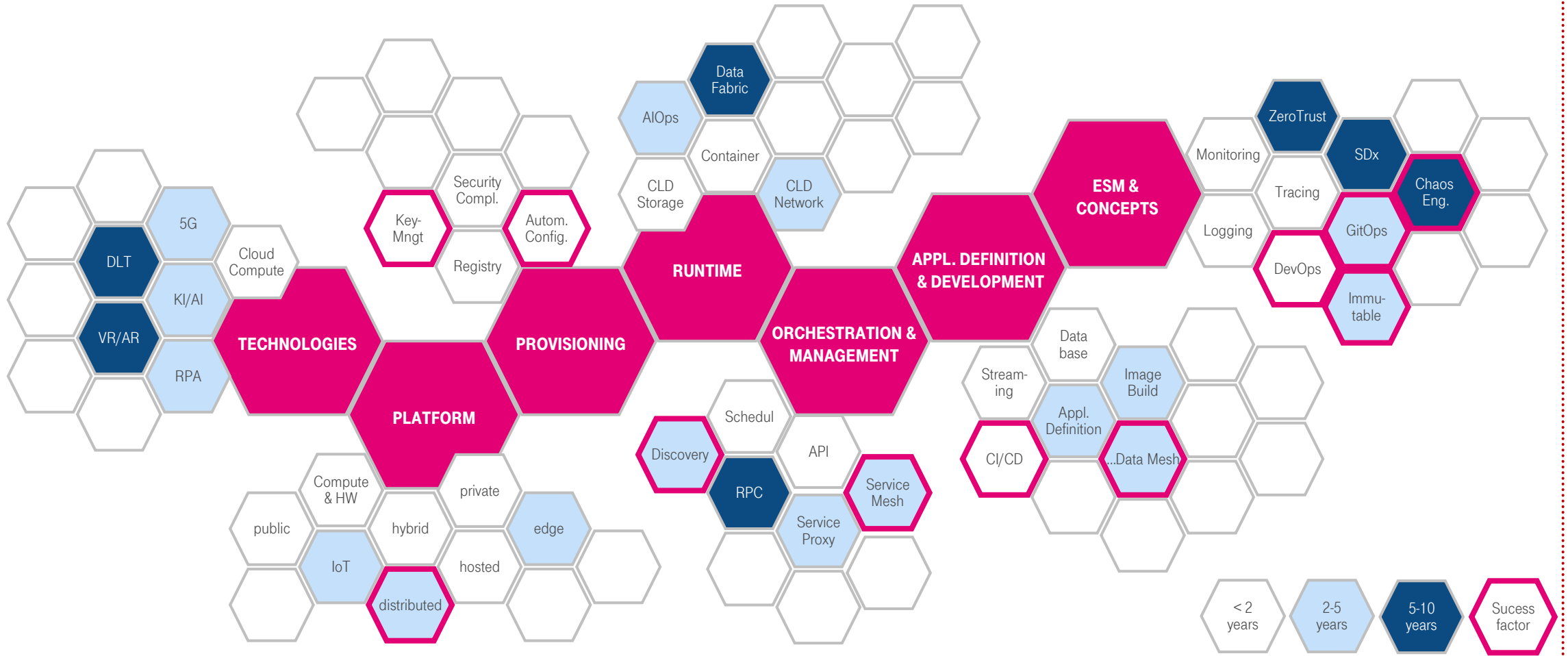

AUTOMATISIERUNG HIN ZUM OPERATOR

Deployment as Code

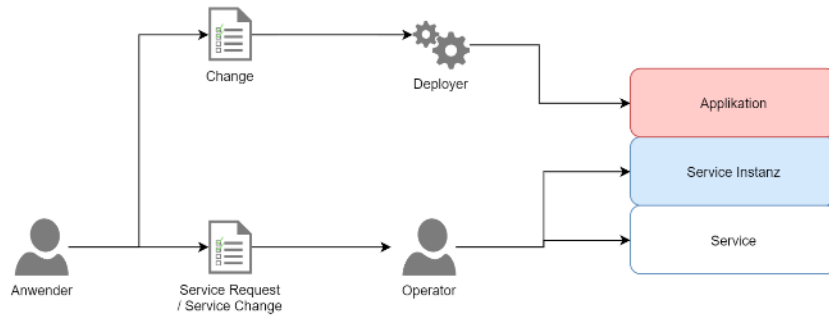

Infrastructure as Code

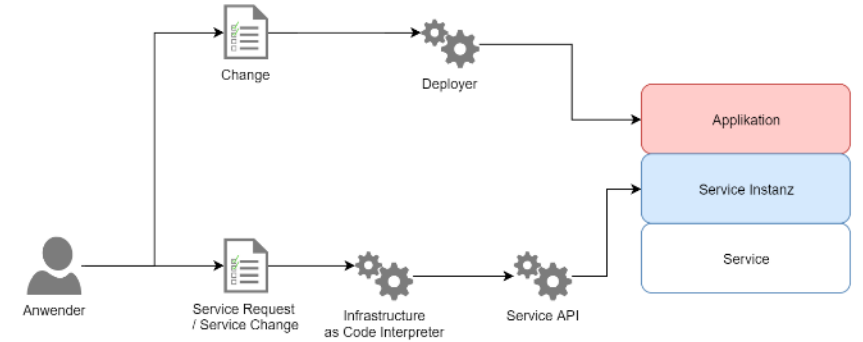

Self-Healing

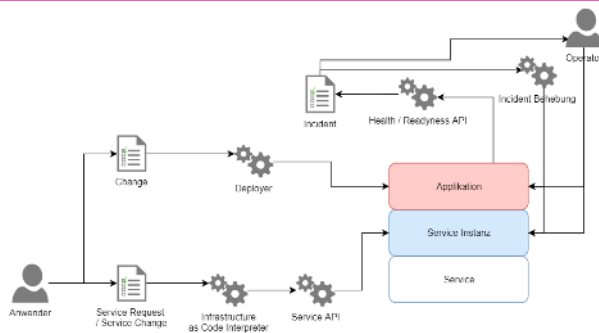

Self-Maintenance

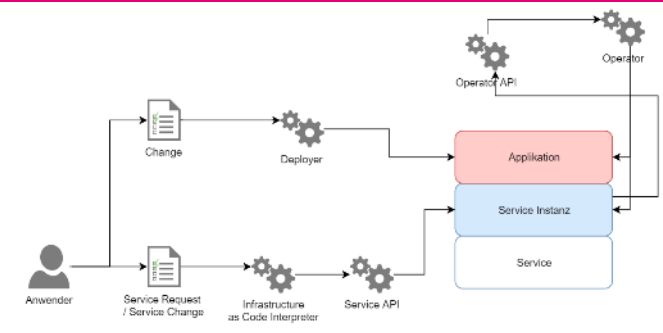

ZUSAMMENARBEITSMODELLE

- **Definition von:**

- SLI – Service Level Indicators
- SLO – Service Level Objectives

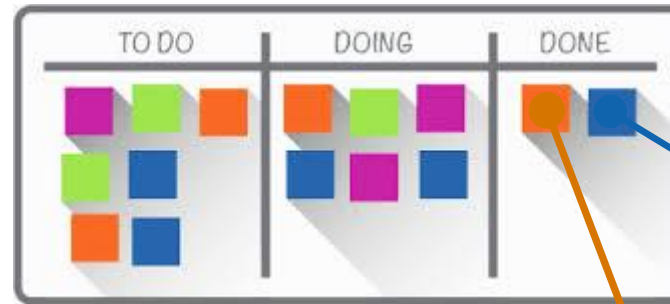

- **Tranzparenz in:**

- Technologie
- Arbeit

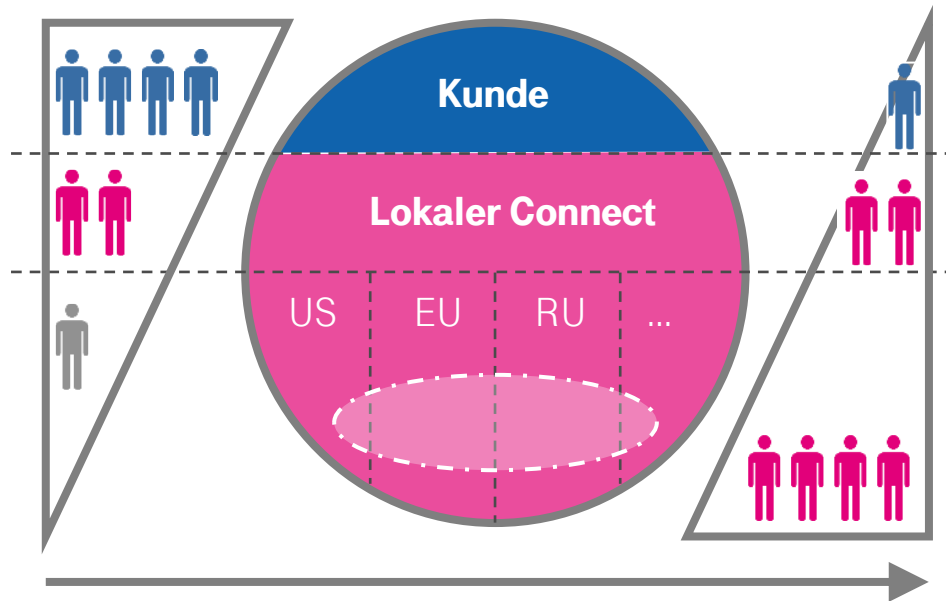

Phase innerhalb eines Tandem Teams



Zusatzaufgaben
«Dev»

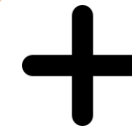

Service Vertrag
«Ops»

Whitebox managed Service

BUSINESS OUTCOME DRIVEN

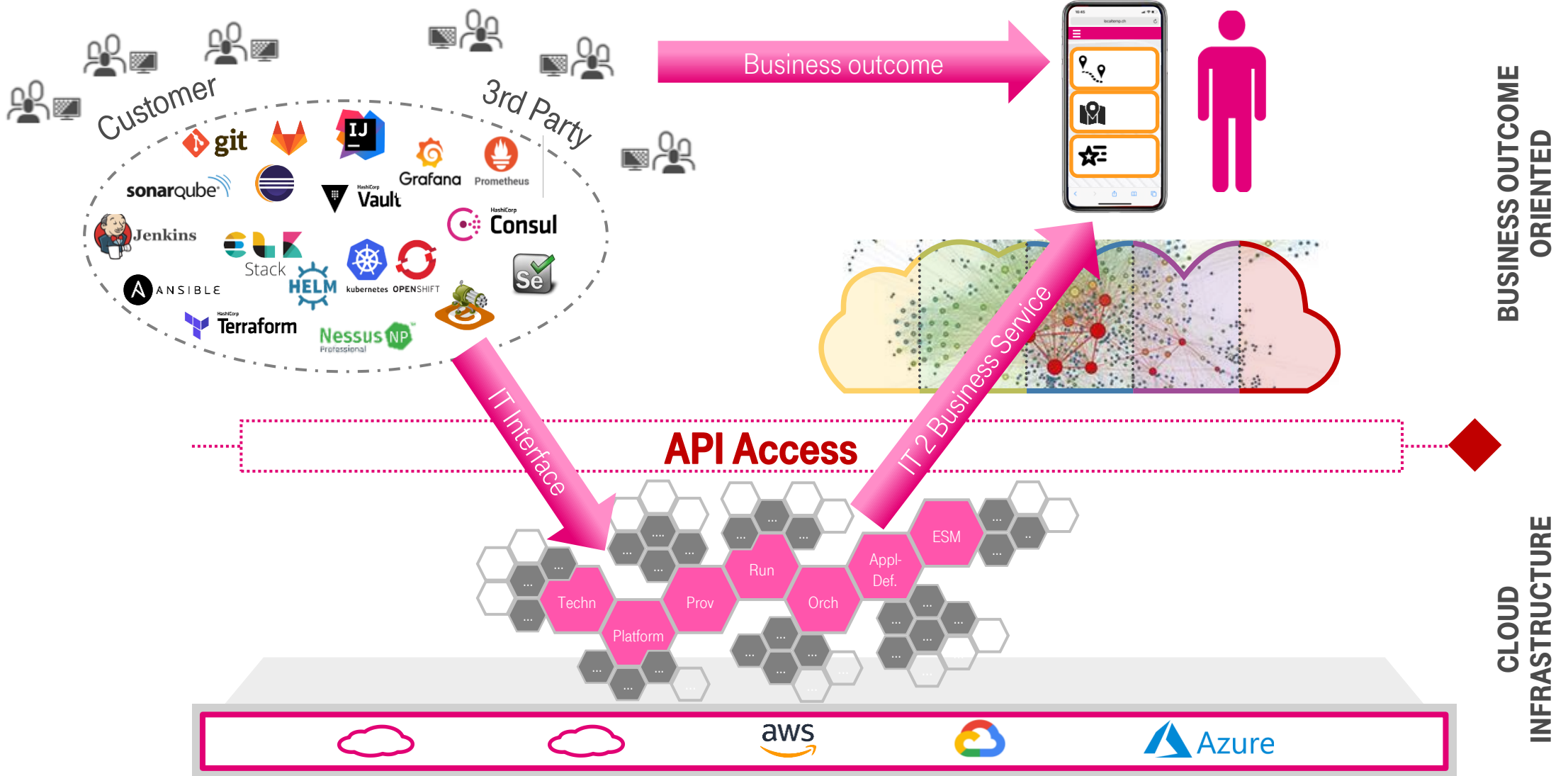

Business Agilität

- Eine breite Palette von verschiedenen unterstützten Cloud Technologien
- Das eingesetzte **Target Operating Model Cloud** ist auf der **Private Cloud** sowie auf der **Public Cloud** identisch



Integration & Zuverlässigkeit

- APIs zur Steuerung von automatisierten Cloud Diensten über die verschiedenen Cloud Plattformen hinweg



IT Sicherheit & IT-Compliance

- umfassende Lösungen für Netzwerke, Cloud-Dienste und Endnutzer-Applikationen



TARGET OPERATING MODEL CLOUD

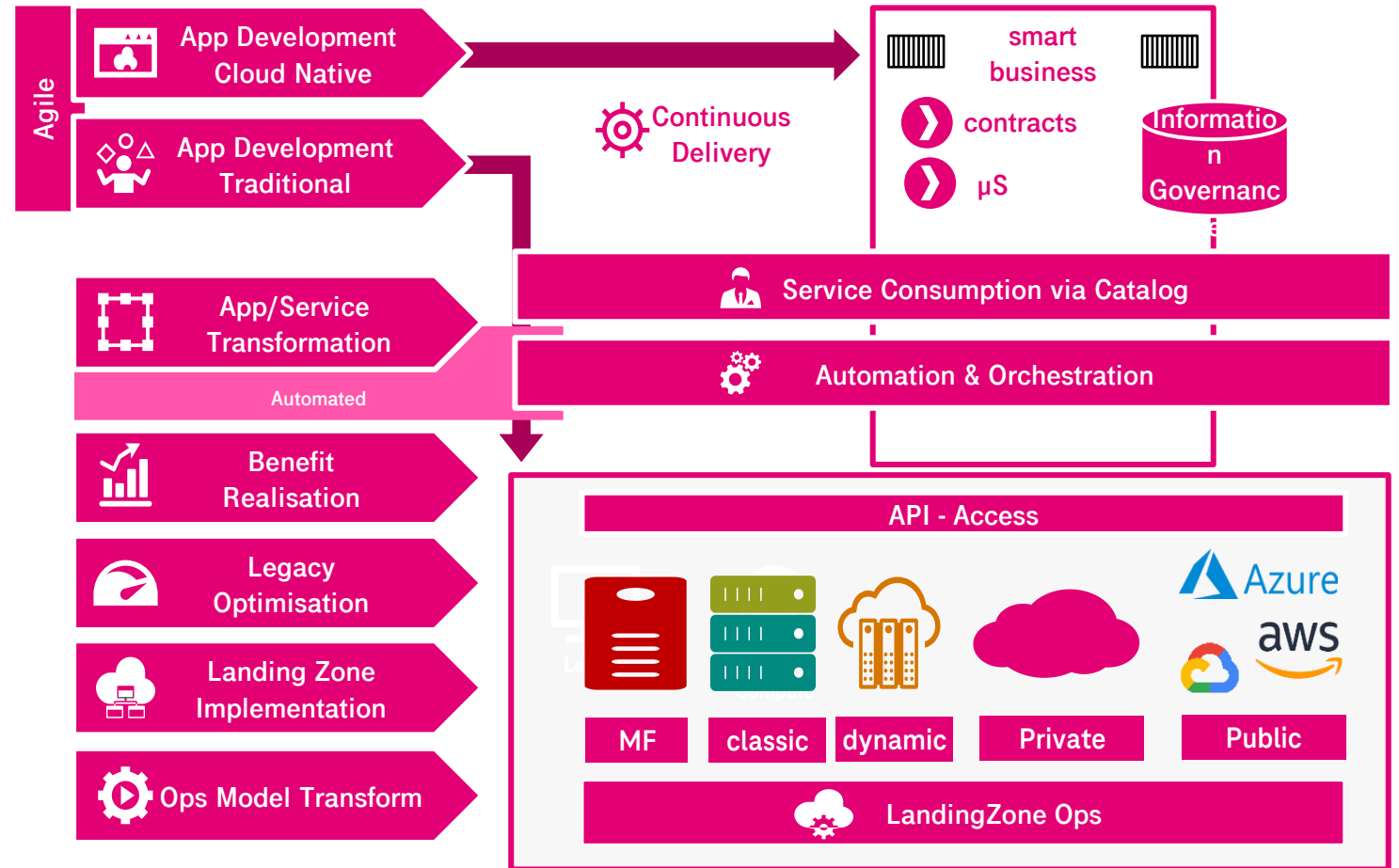



SHIFTING PATTERN

Resilienz & Continuity Management in der Multi-Cloud

Let us do it!



LIFE IS FOR SHARING.